

INSTALLATION GUIDELINES

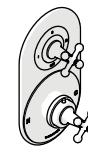

STYLE No. DSTH22

Dash Metal Cross Handle
Thermostatic with Metal Cross
Handle Two Way Diverter Trim



STYLE No. DSTH23

Dash Metal Cross Handle
Thermostatic with Metal Cross
Handle Three Way Diverter Trim

IMPORTANT:

- To ensure this product is installed properly, you must read and follow these guidelines.
- The owner/user of this product must keep this information for future reference.
- This product must be installed by a professional licensed contractor and must be onsite prior to rough-in, this allows the installer to visualize the installation.
- Be sure your installation conforms to federal, state, and local codes. In the State of Massachusetts, all installations must comply with the rules and regulations set forth within 248 CMR.
- This product **MUST BE** installed vertically as shown and **CANNOT** be installed horizontally. This product is intended to work with the Universal Thermostatic Valve with Integrated Two, or Three, Way Diverter Valve (Style No. GUTH49, GUTH50).
- **WARNING:** The GUTH49 and GUTH50 feature anti-scald protection. The risk of scalding exists until the installer has properly calibrated/adjusted the temperature setting during final trim installation.
- Inspect this product to ensure you have all the parts required for proper installation. Product is sold partially assembled but shown fully disassembled for illustrative and service purposes only.
- Use only a strap wrench or protected/smooth-jaw wrench on any finished surface.
- The use of certain plumber's putty may stain stone or tile surfaces.
- If further assistance is required, please contact Product Support at 1-800-927-2120 Monday through Friday, 8am - 6pm EST.
- Refer to the separate Service Parts Documents for available replacement parts.

REQUIRED PLUMBING DETAILS:

- Universal Thermostatic Valve with Integrated Two Way Diverter Valve
STYLE No. GUTH49
- Universal Thermostatic Valve with Integrated Three Way Diverter Valve
STYLE No. GUTH50

ROUGH-IN AND VALVE PREPARATION:

- **CAUTION:** Make sure the supply lines are flushed prior to final TRIM installation using the FLUSH PLATE provided with the VALVE. Refer to the Installation Guidelines provided with the VALVE for further information on how to properly flush the supply lines.

DIM	VALUE
A	3" MIN [76mm]
B	Ø5-1/4" [133mm]
C	Ø2-1/2" [64mm]

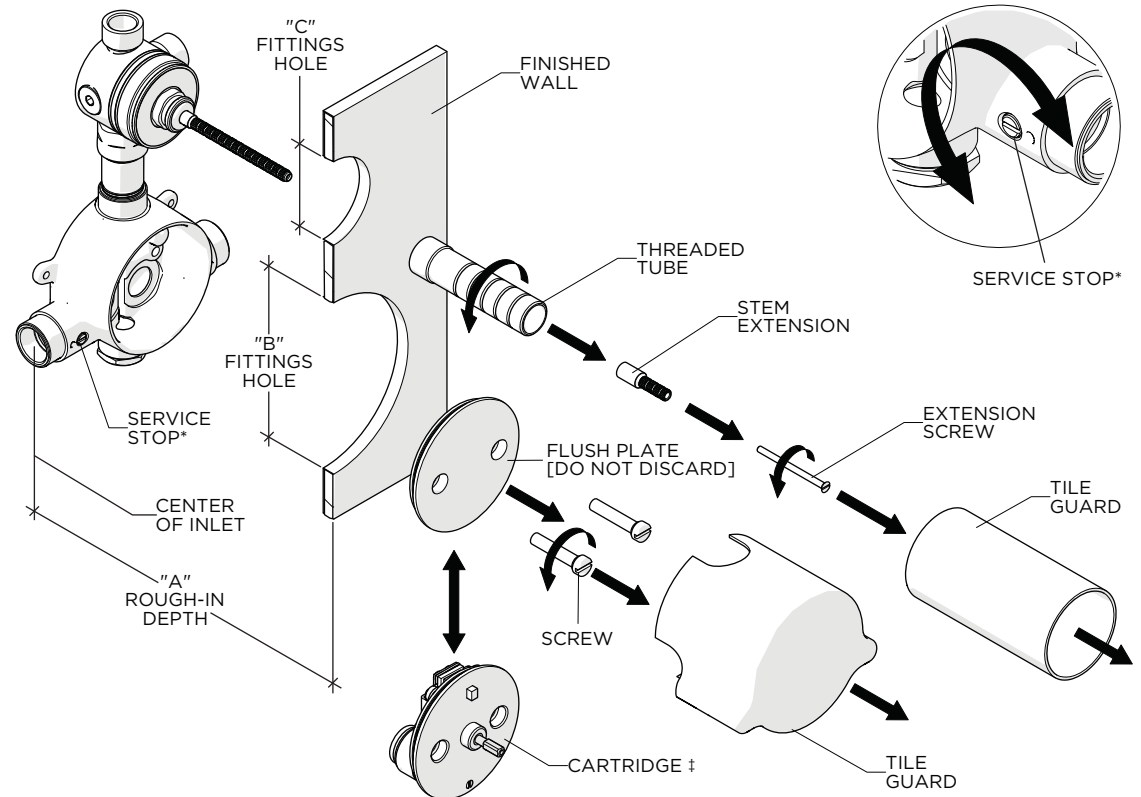

[GUTH49 SHOWN]

‡ **IMPORTANT:** The CARTRIDGE is packaged separately and provided with the VALVE.

INSTALLATION GUIDELINES

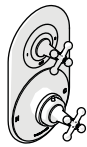

STYLE No. Dsth22

Dash Metal Cross Handle
Thermostatic with Metal Cross
Handle Two Way Diverter Trim



STYLE No. Dsth23

Dash Metal Cross Handle
Thermostatic with Metal Cross
Handle Three Way Diverter Trim

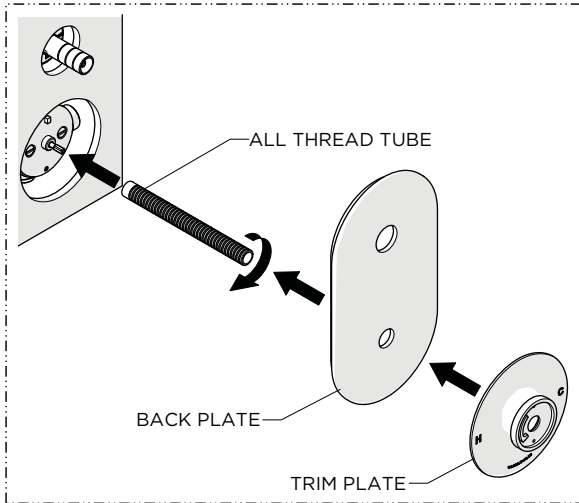

1. Thread the ALL THREAD TUBE onto the THERMOSTATIC CARTRIDGE then slide the BACK PLATE and TRIM PLATE over the TUBE.

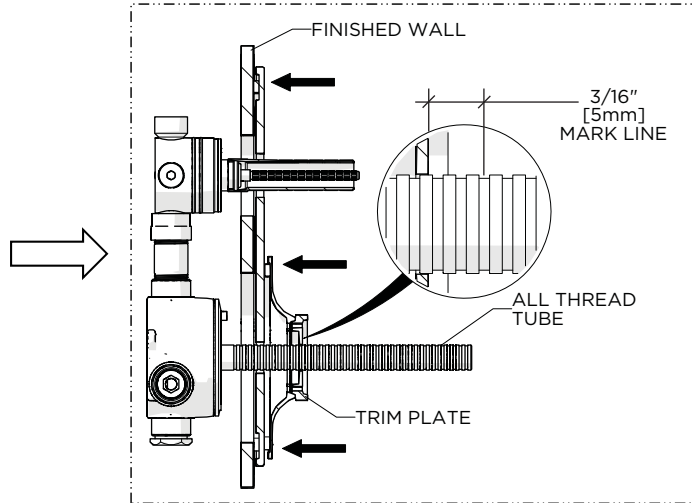

2. Firmly holding the PLATES against the finished wall, mark the TUBE 3/16" [5mm] beyond where it protrudes from the TRIM PLATE.

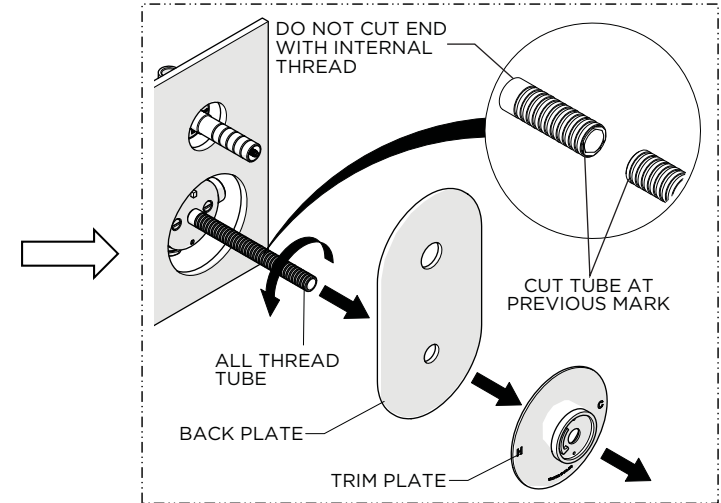

3. Remove the PLATES and ALL THREAD TUBE then cut the TUBE at the previous mark.

NOTE: Do NOT cut the end with internal threads.

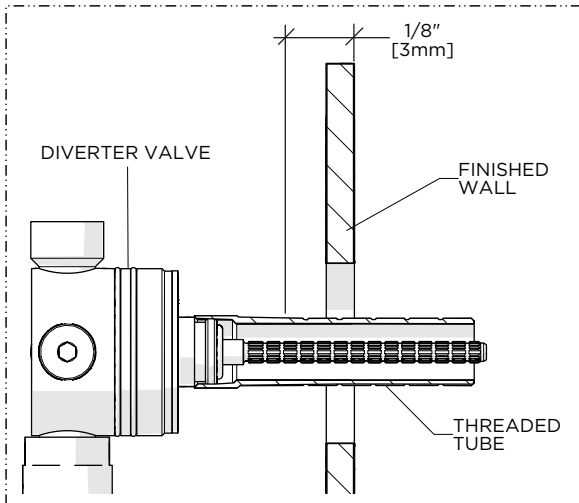

4. Mark the THREADED TUBE 1/8" [3mm] behind the finished wall.

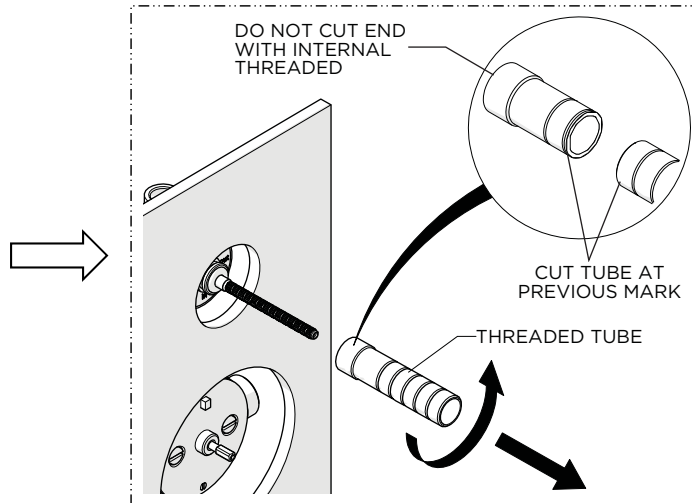

5. Remove then cut the THREADED TUBE at the previous mark.

NOTE: Do NOT cut the end with the internal thread.

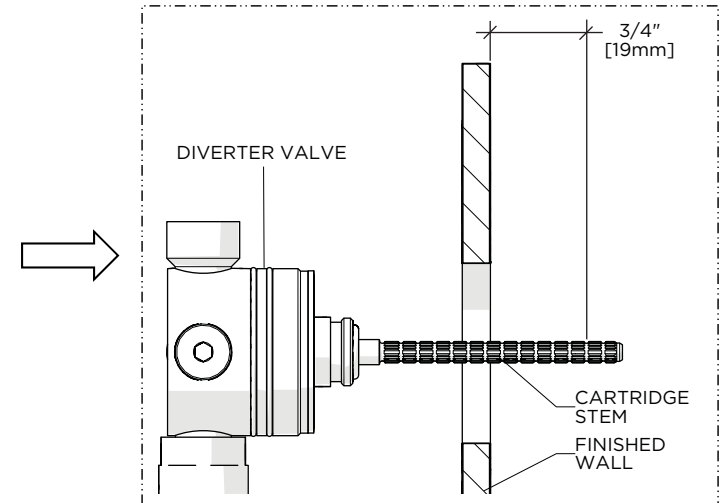

6. Mark the DIVERTER VALVE CARTRIDGE STEM 3/4" [19mm] beyond where it protrudes from the finished wall.

INSTALLATION GUIDELINES

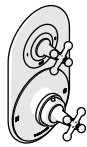

STYLE No. DSTH22

Dash Metal Cross Handle
Thermostatic with Metal Cross
Handle Two Way Diverter Trim



STYLE No. DSTH23

Dash Metal Cross Handle
Thermostatic with Metal Cross
Handle Three Way Diverter Trim

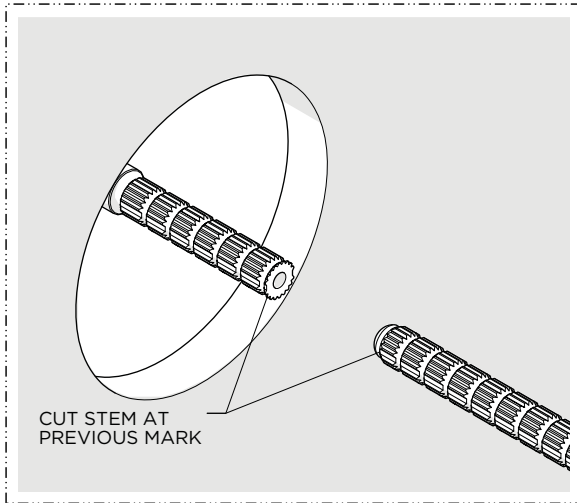

7. Cut the CARTRIDGE STEM at previous mark.

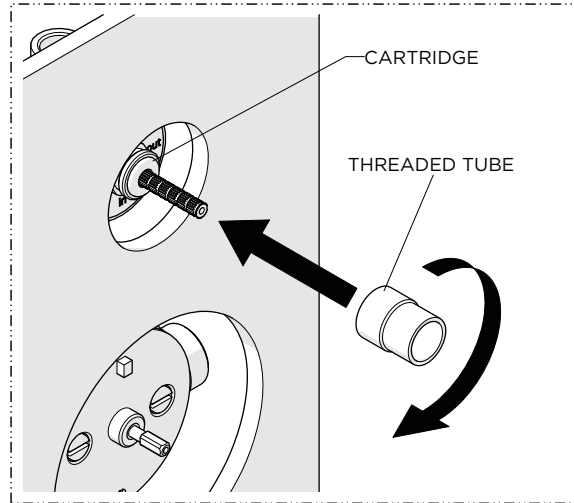

8. Thread and securely tighten the THREADED TUBE back onto the DIVERTER VALVE CARTRIDGE.

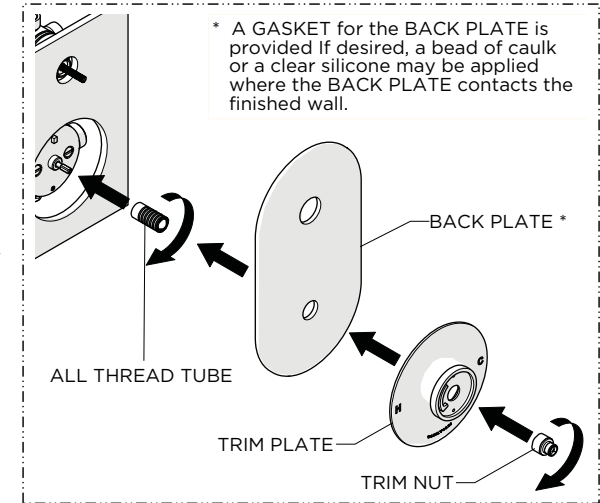

9. Thread the ALL THREAD TUBE back onto the THERMOSTATIC CARTRIDGE, slide the BACK and TRIM PLATES over the TUBE then thread and securely tighten the TRIM NUT onto the TUBE to hold the PLATES against the finished wall.

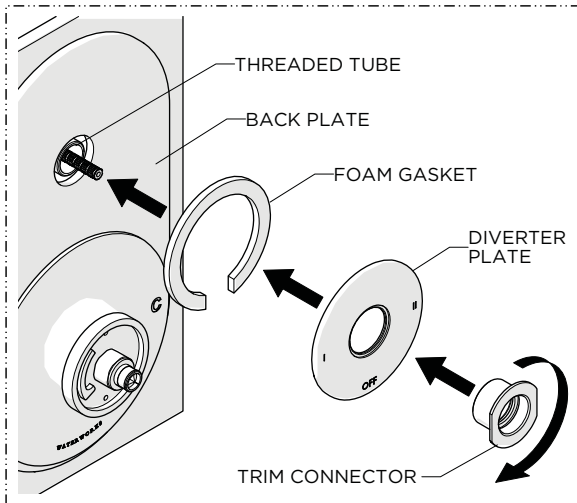

10. Holding the DIVERTER PLATE against the BACK PLATE, thread and securely tighten the TRIM CONNECTOR onto the THREADED TUBE.

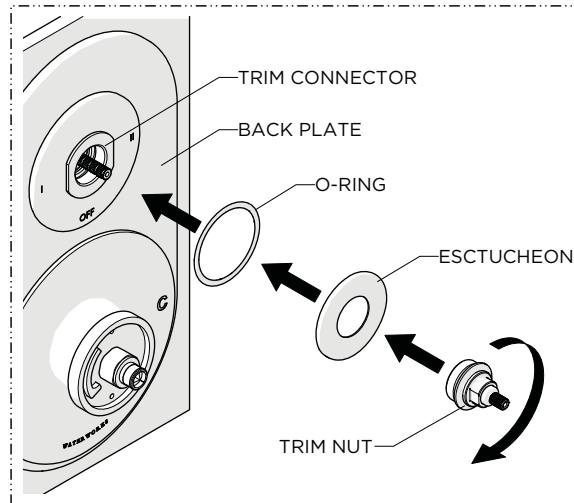

11. Holding the ESCUTCHEON against the DIVERTER PLATE, thread and securely tighten the TRIM NUT into the TRIM CONNECTOR using a 5/8" [16mm] wrench and making sure to use O-RING provided.

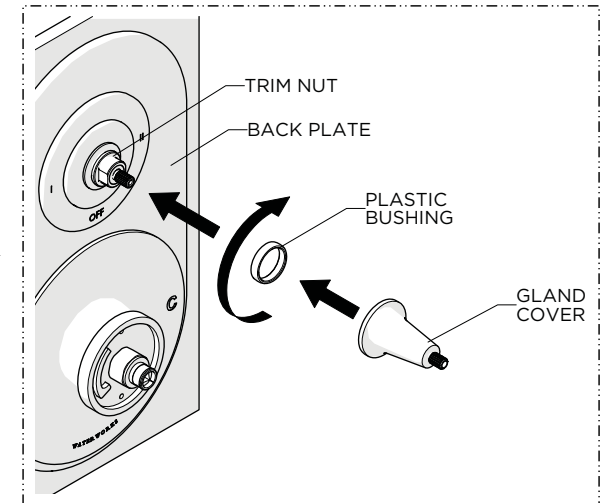

12. Thread the PLASTIC BUSHING onto the TRIM NUT then place the GLAND COVER onto the NUT making sure it is fully seated.

INSTALLATION GUIDELINES



STYLE No. DSTH22

Dash Metal Cross Handle
Thermostatic with Metal Cross
Handle Two Way Diverter Trim



STYLE No. DSTH23

Dash Metal Cross Handle
Thermostatic with Metal Cross
Handle Three Way Diverter Trim

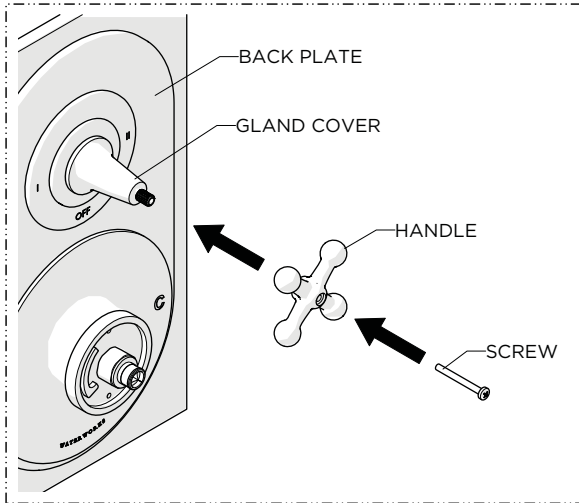

13. Place the HANDLE onto the GLAND COVER in the desired orientation then thread and securely tighten the FINISHED SCREW.

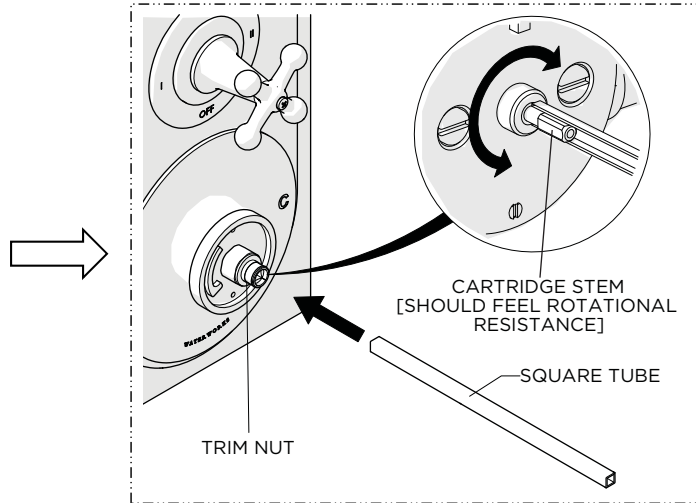

14. Insert the SQUARE TUBE into the TRIM NUT then, by feel, make sure it slides over the CARTRIDGE STEM and is fully seated.

NOTE: When seated properly, the TUBE will have rotational resistance.

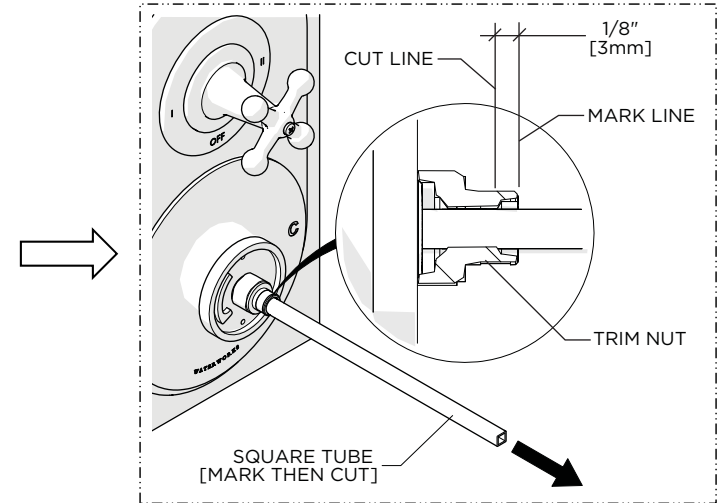

15. Mark the SQUARE TUBE where it passes through the front face of the TRIM NUT then remove and cut the TUBE 1/8" [3mm] behind the mark.

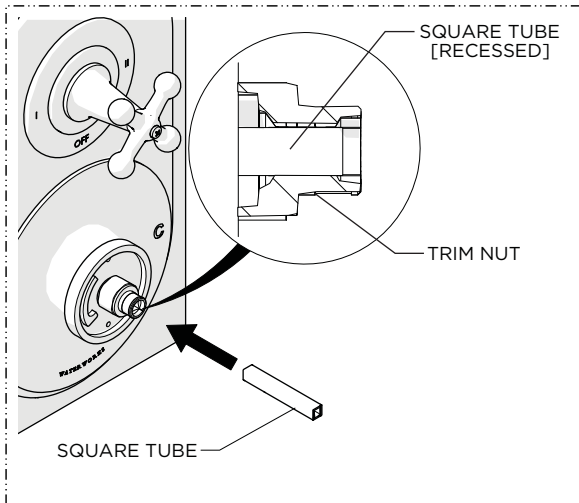

16. Re-insert the SQUARE TUBE back into the TRIM NUT making sure it is slightly recessed.

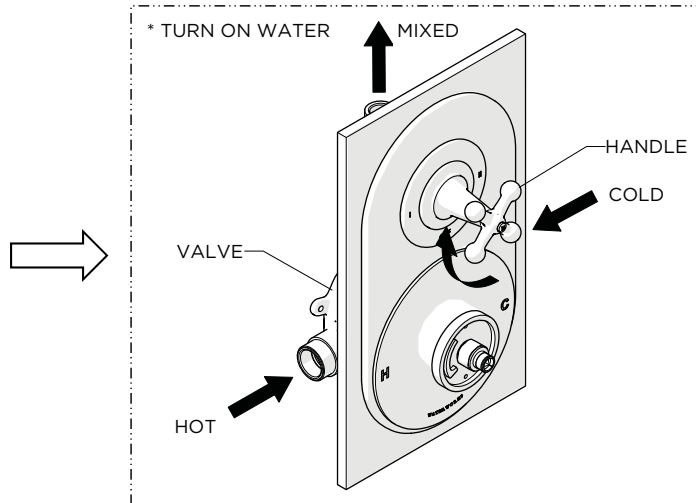

17. Turn on the water supply and open the DIVERTER VALVE to run water through the THERMOSTATIC VALVE.

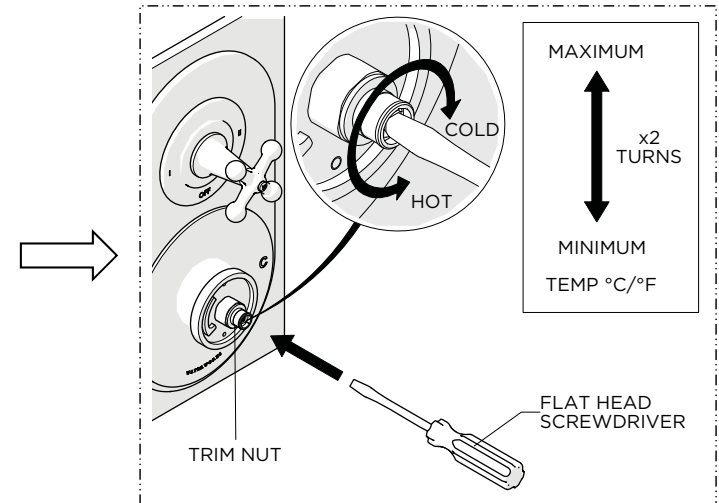

18. Insert a bladed screw driver into the SQUARE TUBE and slowly rotate the TUBE clockwise to attain full cold then counterclockwise to attain full hot. It's approximately 2 complete rotations. Verify a full range of temperatures exists.

INSTALLATION GUIDELINES

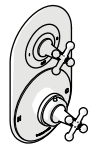

STYLE No. DSTH22

Dash Metal Cross Handle
Thermostatic with Metal Cross
Handle Two Way Diverter Trim

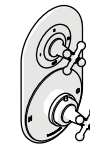

STYLE No. DSTH23

Dash Metal Cross Handle
Thermostatic with Metal Cross
Handle Three Way Diverter Trim

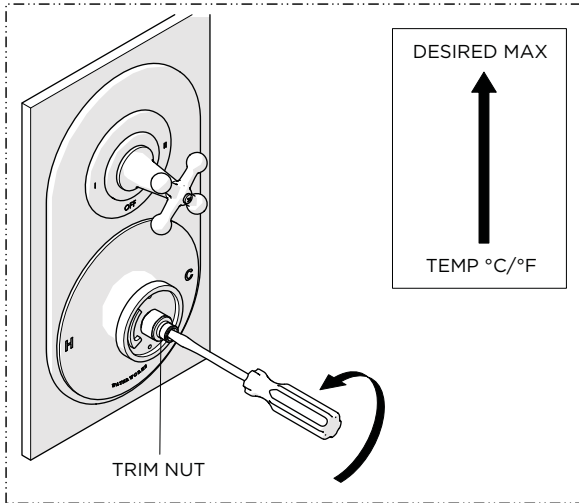

19. With water running, rotate the SQUARE TUBE to adjust the temperature to the **MAXIMUM** desired bathing temperature, verified with a thermometer, then turn the water off and make sure not to change this setting.

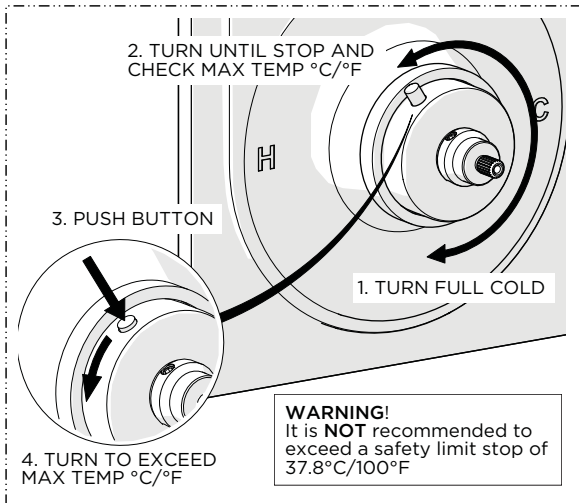

22. Turn the LIMIT STOP to cold then hot and confirm it is functioning properly. Verify the **MAXIMUM** desired bathing temperature. To get a hotter temperature, press and hold the LIMIT STOP BUTTON and turn the LIMIT STOP further.

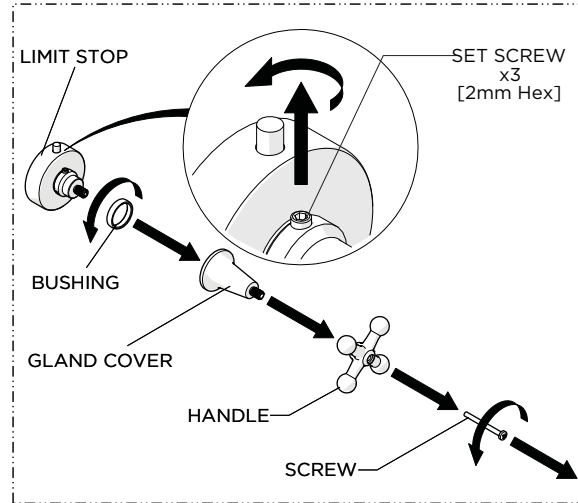

20. Unthread the SCREW, remove the HANDLE, remove the GLAND COVER, and unthread the BUSHING to expose the SET SCREWS on the LIMIT STOP then loosen the SCREWS using a 2mm hex key.

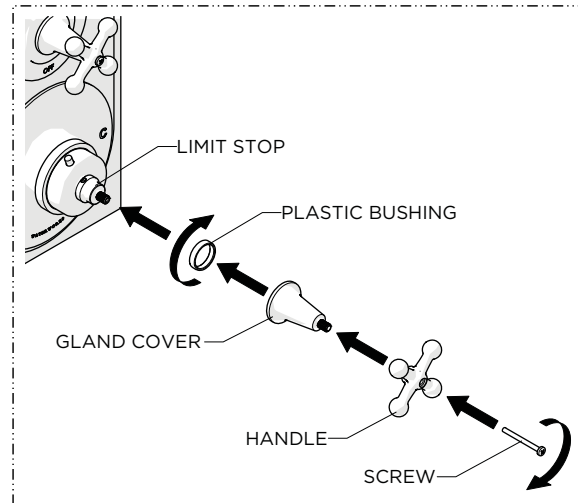

23. Thread the BUSHING back onto the LIMIT STOP, place the GLAND COVER onto the LIMIT STOP and over the BUSHING, place the HANDLE onto the GLAND COVER in the desired orientation, then thread and securely tighten the SCREW.

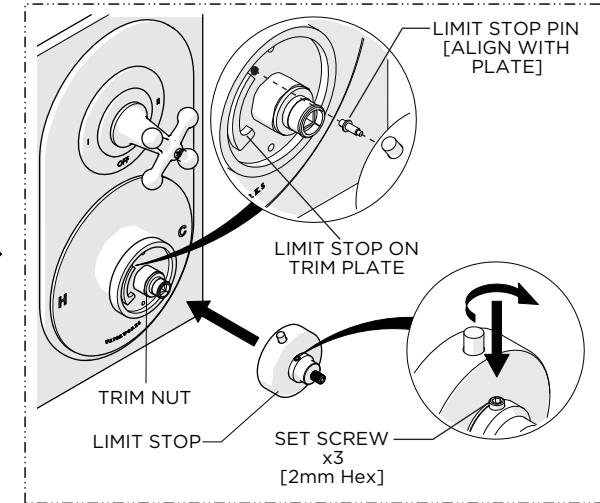

21. Place the LIMIT STOP over the TRIM NUT making sure the LIMIT STOP PIN makes contact with the LIMIT STOP on the TRIM PLATE then tighten the SET SCREWS.

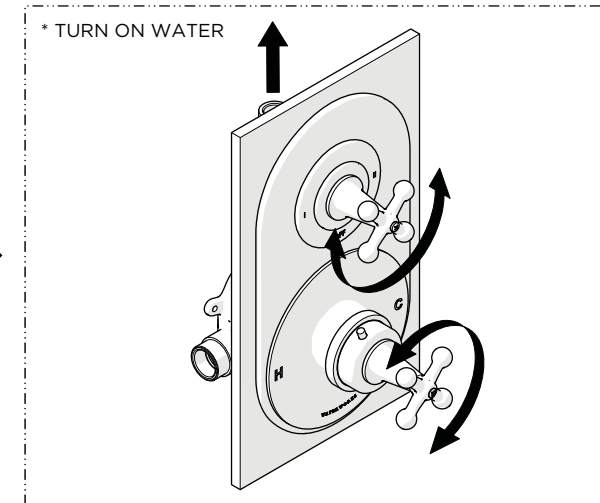

24. Turn on the water supply and operate the HANDLES to ensure that they are functioning properly.